



AC700 User Manual



AC700 Material Sensor User Manual



About AC700 User Manual

Content and structure

This user manual for AC700 has been developed for the operator to provide the necessary information to operate the material controller/sensor.

The Danish version of this manual constitutes the original version, and can therefore be used as a reference in case of doubt regarding use or misuse of the system.

The user manual is a practical guide for setup, mounting, operating and maintaining the AC700. The user manual has been divided into colour-coded sections, enabling the user to easily look up the potential subjects of interest.

Safe use

Before AC700 is operated, this user manual should be studied carefully to ensure correct and safe use of the system. Particularly the section Safety Instruction, p. 23 should be read thoroughly before use.

Getting thoroughly acquainted with the manual furthermore ensures the operator the full value of the AC700, as the user manual also contains useful guidance on maintenance and troubleshooting. The user manual should always be stored together with the AC700.

To ensure safe use of the AC700, the operator is advised to perform an individual risk assessment of the use of the AC700 in combination with the relevant asphalt paver.

The AC700 is CE-marked and comply with regulations for security and reliability.

Copyright

This manual has been developed exclusively for users of the AC700 to provide the necessary information to operate the AC700, and may only be used for this particular purpose. All information, text and pictures are the intellectual property of, and copyrighted material of TF-Technologies A/S. All rights are reserved. The manual may not be copied, displayed, quoted, published, sold, modified, or distributed without the written consent of TF-Technologies A/S.

Disclaimer

TF-Technologies A/S and its distributors may not be held liable for potential editorial errors, omissions or failure effects. Suggestions regarding updates or correction of potential errors are appreciated.

Contact information

TF-Technologies A/S
Kratbjerg 214
3480 Fredensborg
Denmark
T: +45 4848 2633
E: sales@tf-technologies.com

User manual information

Document name: AC700 User Manual
Document number: G701304
Publication date: 07. February 2022

AC700 Material Controller/Sensor

Every AC700 unit contains a model number/ name, type number, serial number and part number, so that each unit is easily identified and traceable. The cables for AC700 are also provided with part numbers. All relevant numbers should be stated, when contacting TF-Technologies regarding your product:

Example

Model number/name: AC700
 Type number: T1
 Serial number: TF-47305
 Part number: S-50631

Example AC700 cable

Part number: S-50662

The AC700 versions and the associated cables are adapted to specific pavers. When contacting TF-Technologies or your local representative for ordering or support, the following relevant information should be stated for both the paver and any existing material controller/sensor:

Information about the asphalt paver:

- Manufacturer
- Model number
- Production year
- Type of plug (e.g screw plug or bayonet plug)
- Machine plug (number of pins)
- Type of valve (ON/OFF or proportional)
- Use (auger or conveyor belt)

Information about previous material controller/sensor:

- Manufacturer
- Part number
- Type of plug (e.g screw plug or bayonet plug)
- Plug (number of pins)
- Type of valve (ON/OFF or proportional)

Symbol overview

This user manual uses a range of symbols and warning notifications throughout the manual to make the operator aware of important safety measures or information regarding operation. The following symbols are used in this manual:



Warning!

Indicates important information the operator must be aware of to avoid dangerous situations which can result in death or serious personal injury



Caution!

Indicates important information the operator must be aware of to avoid dangerous situations which can result in material damages



Step-by-step instructions

Indicates a step-by-step instruction, where a particular order of actions is required or recommended

Table of Contents

About AC700 User Manual 4

Introduction

Introduction to AC70010
Material Feed13
Material Distribution14
Material Control with AC70015

Operation

Operating the AC700 Material Controller18
Reading the AC700 Material Controller19
Error Codes of the AC700 Material Controller20
Reading the AC700 Material Sensor21
Error Codes of the AC700 Material Sensor21

Safety Instruction

Asphalt Paver Requirements24
Correct Use26
Responsibility of the Operator27
Examples of Incorrect Use29
Warnings and Dangerous Situations31
Emergency Procedure33

Mounting the AC700

Choosing Place of Operation36
Placing the AC70038
Incorrect Placement of the AC70039
Mounting the AC70040

Connecting the AC700

Cables and Connections44
Safe Connection and Disconnection45

Maintenance

Maintenance50
Inspection50
Service and Repair51
Transport54
Storage55
Cleaning56
Disposal57

Appendix

Technical Specifications (data sheets)60
Declarations of Conformity73







Introduction

Introduction to AC700	10
Material Feed	13
Material Distribution	14
Material Control with AC700	15

Introduction to AC700

About AC700

The AC700 ensures optimal feed and distribution of the asphalt hot mix, so that the material is distributed evenly across the screed providing a key precondition for a smooth road finish.

Too much material in front of the screed can lead to temperature drops and material clumping, while too little material in front of the screed can lead to inadequate pre-compaction, both of which will result in an uneven road surface. A changing amount of material in front of the screed affects its ability to float, which also leads to an uneven road surface.

With AC700 material control a constant head of material in front of the screed is secured which eliminates these problems.

Two basic versions of the AC700

There are two basic versions of the AC700: One version where sensor and controller is built into one unit and one version where the AC700 only works as a sensor, which is connected to a controller on the asphalt paver. The controller can be integrated into the paver or retrofitted.

The AC700 material sensor must be connected to the controller of the asphalt paver and operated from there, whereas the AC700 material controller, with sensor and controller built into one unit, is operated directly from the unit.

The front panel of the AC700 material controller features pushbuttons for easy and simple operation, as well as display for the indication of settings and error codes. The AC700 material sensor features a single green LED to indicate whether the unit is operating correctly.



AC700 with sensor and controller – AC700 material controller



AC700 with sensor – AC700 material sensor

Specialized AC700 types

Asphalt pavers from different manufacturers use different signals and plugs for the connection of material controllers/sensors. The AC700 therefore exists in a number of types with different specifications, modified to different types of asphalt pavers.



Selection of different AC700 types

The AC700 type is easily identified on the back of the unit, as each type of AC700 has its own type number visible on the product label on the back of the unit.



AC700 with type number T1

Likewise, a broad range of different AC700 cables is available, customized for the various types of AC700 and the different types of asphalt pavers. The operator must always ensure that the correct type of AC700 is connected with the correct type of cable.

Choosing type of AC700

The correct choice of AC700 type and cable type is determined by the specific asphalt paver the unit is to be mounted on. Upon ordering or requesting support, the operator must specify the following relevant information about the asphalt paver, for TF-Technologies or the local representative to inform which AC700 type and cable type should be used on the particular asphalt paver.

Information about the asphalt paver:

- Manufacturer
- Model number
- Production year
- Type of plug (e.g screw plug or bayonet plug)
- Machine plug (number of pins)
- Type of valve (ON/OFF or proportional)
- Use (auger or conveyor belt)

If an alternative material controller/sensor is already mounted on the asphalt paver, it can be easier to access information about this. In most cases TF-Technologies or a local representative will be able to inform which type of AC700 and which type of cable that can replace the existing or previously used equipment. In such case, the following information must be specified.

Information about previous material controller/sensor:

- Manufacturer
- Part number
- Type of plug (e.g screw plug or bayonet plug)
- Plug (number of pins)
- Type of valve (ON/OFF or proportional)

Available specifications

The AC700 types available are able to manage most types of control signals, including:

- **ON/OFF, as NPN or PNP**
- **PWM, as NPN eller PNP**
- **Current output**
- **Voltage output**

The AC700 types and cable types available feature various types of plugs, including:

- **Bayonet plug and screw plug**
- **Different pin-out**

All available AC700 types can be used for asphalt pavers with 12 volt or 24 volt power supply.

- **Input: 10 – 30 VDC**

Simple connection

Once the operator has made sure he has the correct type of AC700 and the correct type of cable, the equipment can be connected and used immediately.

The AC700 automatically starts up when power is applied, and the operator does not need to adjust anything but the desired level of material.

Years of experience provide reliable and durable design

Based on experience with asphalt work since 1978, the AC700 has been designed specifically for the rough environmental conditions present in asphalt paving. The unit is composed of a strong aluminium casting resistant to corrosion and tough handling, and the electronics inside are encapsulated in silicone ensuring protection against water and moisture.

Material Feed

Paving asphalt with a smooth surface requires a constant head of material in front of the screed as displayed in figure 1. The asphalt hot mix is delivered in the hopper (1) in the front of the asphalt paver, after which it is transported with the conveyor belts (2) to the augers (3) that distribute

the material in front of the screed (4). The screed smoothens out the material and pre-compacts it with heat, vibrations and tampers, so that the asphalt obtains the optimal degree of compaction before the rollers finalize the asphalt job.

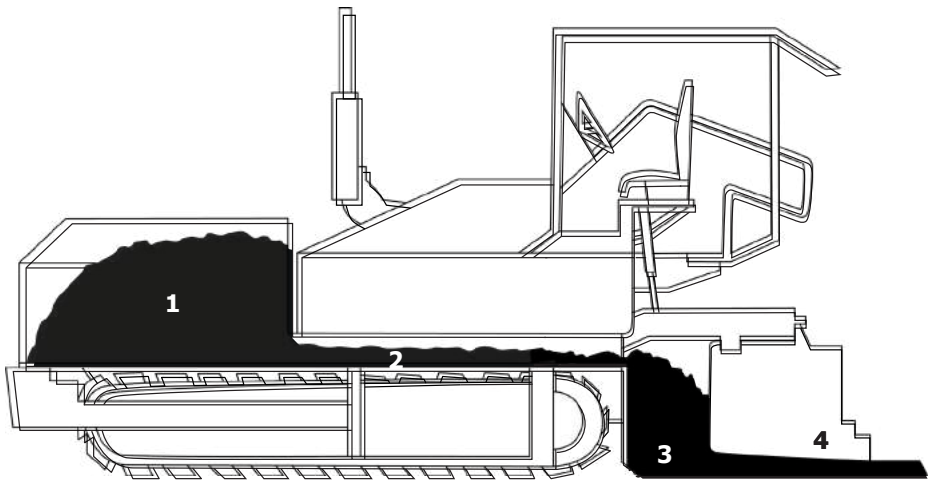

Figure 1 - Transport of material through the asphalt paver

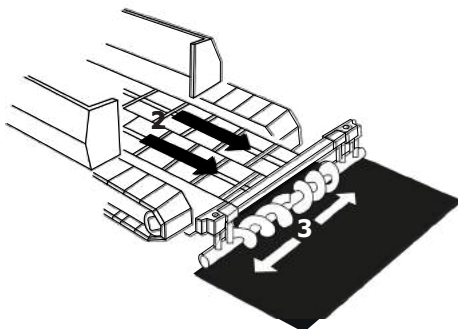

Figure 2 - Distribution of material in front of the screed

A constant head of material in front of the screed is obtained by regulation of the speed of the conveyor belts and augers, so that the material feed is adjusted to the paving job at hand. This is best done with an automatic material feeding system, where a sensor monitors the amount of material and automatically adjusts the feed to a level set by the operator.

The asphalt paver consists of two identical sides as displayed in figure 2. The two conveyor belts (2) and the two augers (3) are all regulated independently of one another, and therefore require its own monitoring and regulation of material feed.

Material Distribution

The job for any type of material control is to secure the correct amount and distribution of material in front of the screed.

Ideal material distribution

The material reaches out to the side plates and the augers are not buried in material. The level of material is constant across the entire screed, which is a precondition for a smooth road surface. (At the very end of the screed on each side at the side plates, the level of material is naturally not nearly as high as at the augers).

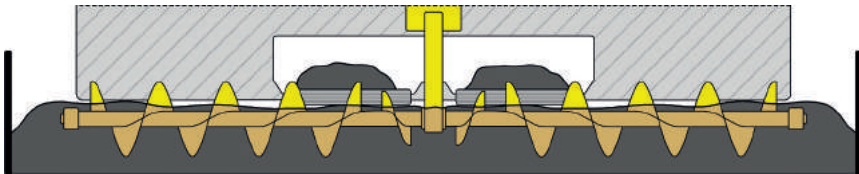

Figure 3 - Ideal material distribution for both conveyor belts and augers

Too little material distribution from the augers

The level of material in front of the screed is uneven. The material does not reach out all the way to the side plates, and the level of material at the augers is too high.

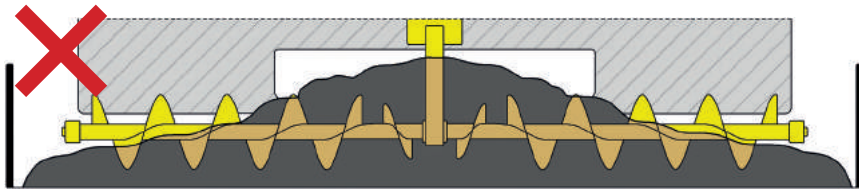

Figure 4 - Too little material distribution from the augers

Too large material feed from the conveyor belts

The level of material in front of the screed is uneven. There is too much material in the middle, at the conveyor belts.

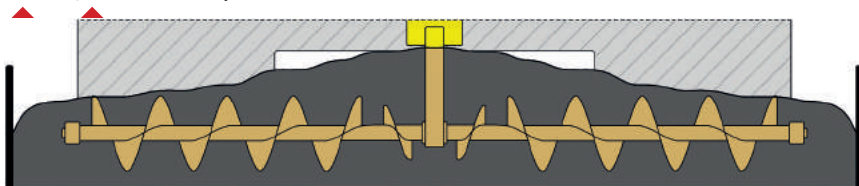

Figure 5 - Too large material feed from the conveyor belts

Too large material feed from the augers and/or too little material feed from the conveyor belts

The level of material in front of the screed is uneven. There is too much material in the sides at the side plates, and too little material in the middle at the conveyor belts.

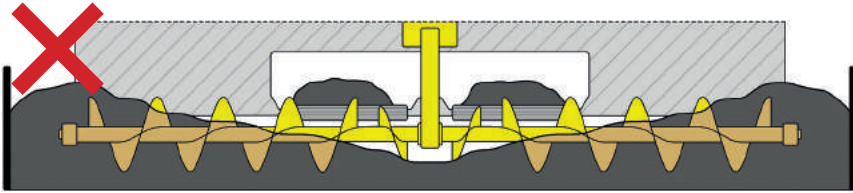

Figure 6 - Too large material feed from the augers and/or too little material feed from the conveyor belts

Material Control with AC700

With AC700 material control the optimal control of material feed is obtained, securing a constant and even distribution of material.

The AC700 is based on ultrasound, a contact-free technology that eliminates the typical problems of direct contact with mechanical material control that often get caught in the sticky material and lose its functionality.

The AC700 can be used for regulation of both conveyor belts and augers, so that the screed is constantly supplied with an adequate amount of material across its full length which is a key precondition for a smooth road surface.

Since the two conveyor belts and two augers of an asphalt paver are controlled independently of one another, up to four AC700 units may be required on one asphalt paver. Each AC700 unit is connected to the asphalt paver with a specialty cable adapted to the specific machine plug for material control on the particular asphalt paver.

Whether material control is required on both conveyor belts and augers is determined by the type of asphalt paver in question.

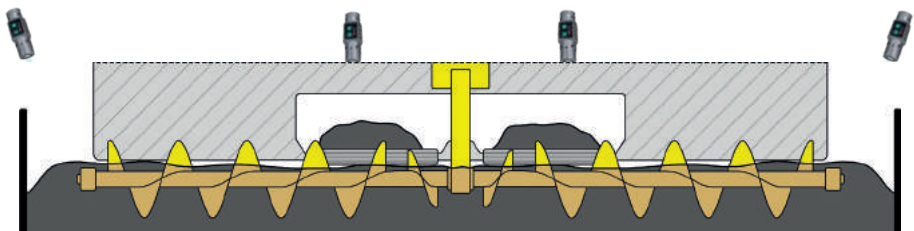
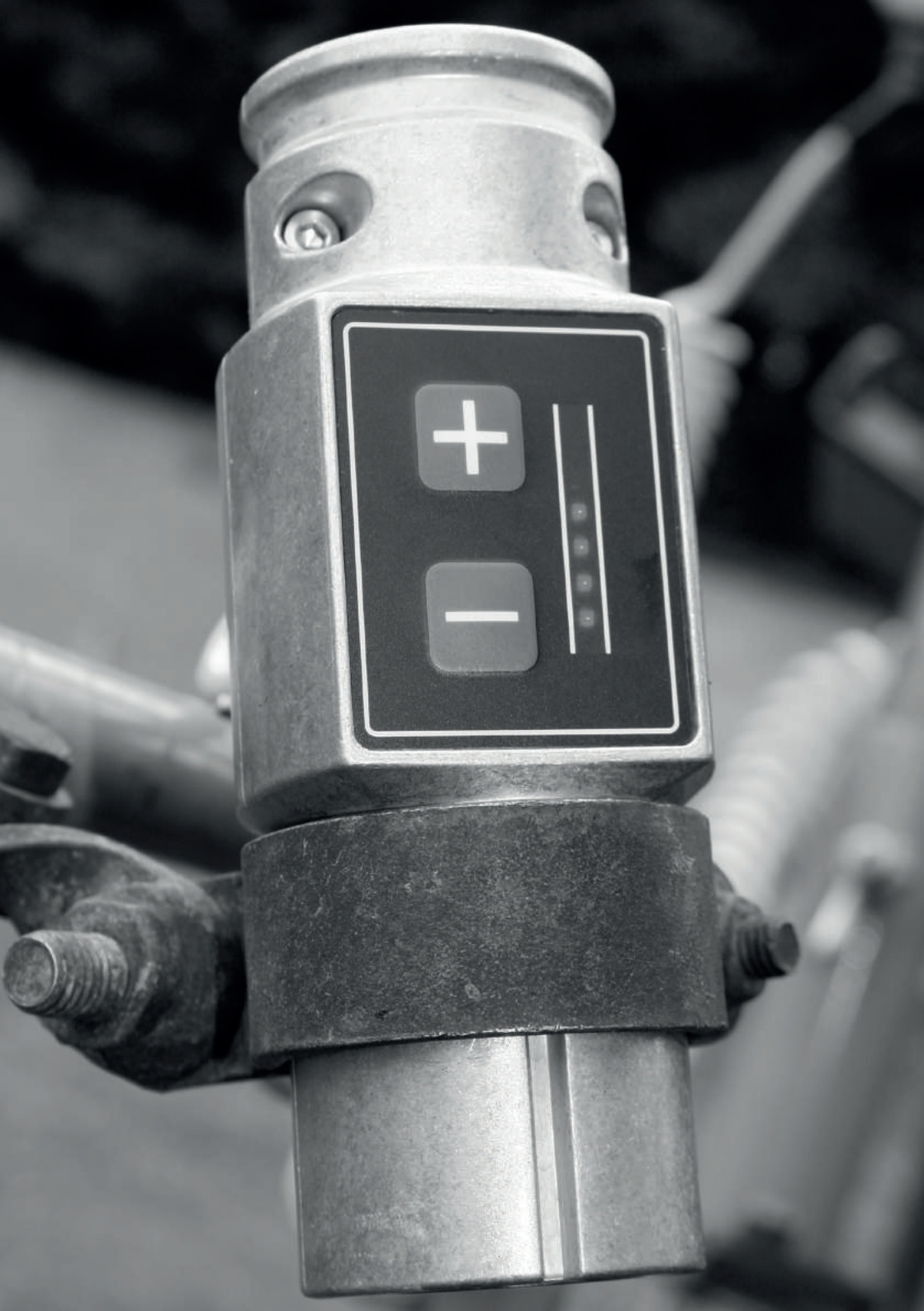

Figure 7 - AC700 controls the material flow on the conveyor belts and augers





Operation

Operating the AC700 Material Controller	18
Reading the AC700 Material Controller	19
Error Codes of the AC700 Material Controller	20
Reading the AC700 Material Sensor	21
Error Codes of the AC700 Material Sensor	21

Operating the AC700 Material Controller

The AC700 material controller contains sensor and controller in one unit. It has an operation panel on the front and a sensor in the bottom measuring the distance to the material.

The sensor range is 200mm to 1000mm / 8" to 40", which means the AC700 must be placed within this distance to the material in order to control the material feed.

The AC700 must be adjusted to a setpoint that provides the desired amount of material in front of the screed. The setpoint corresponds to the distance between the sensor and the material.

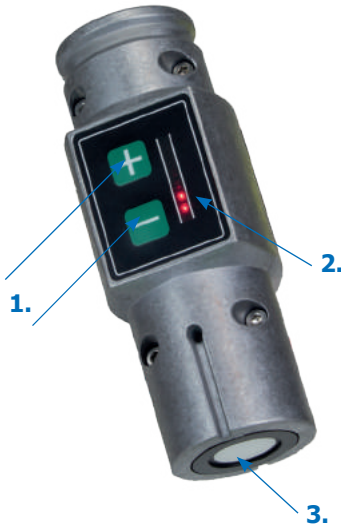

1. Adjusting the setpoint

The level of material can be easily changed with the pushbuttons on the front panel of the AC700.



Increases the level of material - more material.



Decreases the level of material - less material

2. Reading the setpoint

The LED light diodes indicate the setpoint as long as the sensor is operating within its sensor range. The more LEDs turned on, the higher the setpoint and level of material.

3. The ultrasonic sensor

The sensor head must have an unobstructed view to the material, so that the AC700 can freely measure the distance to the material.

Choosing the setpoint

There are 30 steps available for the operator when adjusting the setpoint and the amount of material desired in front of the screed. Each step corresponds to a distance of approximately 21mm / 1" between the sensor and the material. The setpoint can be adjusted within a range of 220mm to 850mm / 9" to 34", and each push on one of the pushbuttons regulates the setpoint one step up or down. For example, it requires five push on the plus-button to increase the level of material with approximately 100mm / 5".

If the AC700 detects a drop in the level of material in respect to the setpoint chosen, it will increase the speed of the auger or conveyor belt, so that more material is fed to the screed and the desired level of material is maintained.

Reading the AC700 Material Controller

When using an AC700 material controller with sensor and controller built into one unit, the operation and adjustment of the level of material takes place on the front panel of the unit.

The setpoint chosen corresponds to the distance between the sensor and the material, and therefore the level of the material fed to the screed.

The setpoint can be adjusted within a range of 220mm to 850mm / 9" to 34", and there are 30 steps available for the operator. The steps are displayed with the LED light diodes of the AC700. The larger the amount of LEDs turned on, the more material is fed to the screed, and the smaller the distance between the sensor and the material.

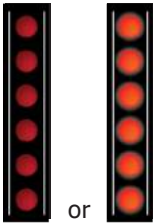

Outer limits of the setpoint

If **all LED light diodes are turned off**, the level of material is at the lowest possible level, corresponding to a distance of 850mm / 34".

- If the operator requires a lower level of material even though all LED light diodes are turned off, the AC700 must be moved closer to the material

If **all LED light diodes are turned on**, the level of material is at the highest possible level, corresponding to a distance of 220mm / 9"

- If the operator requires a higher level of material even though all LED light diodes are turned on, the AC700 must be moved further away from the material

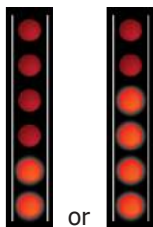

LED light diodes turned on

1/3 of the level of material is displayed with two LEDs
2/3 of the level of material is displayed with four LEDs

The highest available level of material is displayed with all LED light diodes turned on and the lowest available level of material is displayed with all LEDs turned off.

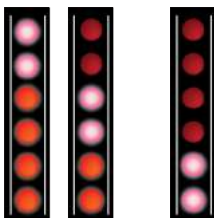

LED light diodes flashing

The setpoint has 30 available steps. If the setpoint is at a level outside the four different indications with LEDs constantly turned on or off, it is indicated with two flashing LEDs.

For example, if the setpoint is larger than 1/3 and smaller than 2/3, two flashing LEDs are added to the two LEDs turned on.

Error Codes of the AC700 Material Controller



'Too close'

If the distance between the material and the sensor becomes **less than 200mm / 8"** the material feed stops in order to protect the AC700 until the level of material has decreased. This is indicated with six flashing LED light diodes

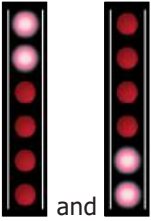

'Out of range'

If the distance between the material and the sensor becomes **more than 1000mm / 40"** the AC700 will continue to feed at the maximum level until the surface of the material can be detected again.

This is indicated with the two top LED light diodes and two bottom LED light diodes flashing alternately.

Reading the AC700 Material Sensor

When using an AC700 material sensor without a built-in controller, the operation and adjustment of the level of material takes place on the controller the unit is connected to. The controller can be integrated into the paver or retrofitted. An AC700 material sensor without controller does not indicate the setpoint.

The sensor range is 200mm to 1000mm / 8" to 40", and the AC700 displays whether it is operating within range, is too close to the material or out of range with a single green LED light diode.

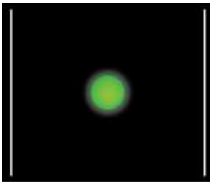

Slow flashes - the diode is turned on and off an equal amount of time

'Within range'

When the sensor is operating between 200mm to 1000mm / 8" to 40" from the material it is operating within its working range and the sensor provides correct measurements.

This is indicated with slow flashes of the green LED light diode, where the diode is turned on and off an equal amount of time.

Error Codes of the AC700 Material Sensor

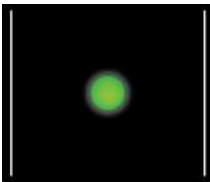

Fast flashes - very short

'Too close'

If the distance between the material and the sensor becomes **less than 200mm / 8"** the AC700 is too close to the material.

This is indicated with fast flashes of the green LED light diode that are very short.

If the operator requires a higher level of material, the AC700 must be moved further away from the material.

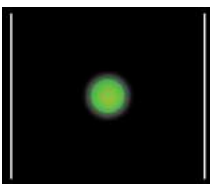

Slow flashes - very short

'Out of range'

If the distance between the material and the sensor becomes **more than 1000mm / 40"** the AC700 is too far away from the material.

This is indicated with slow flashes of the green LED light diode that are very short .

If the operator requires a lower level of material, the AC700 must be moved closer to the material.





Safety Instruction

Asphalt Paver Requirements.....	24
Correct Use.....	26
Responsibility of the Operator	27
Examples of Incorrect Use	29
Warnings and Dangerous Situations.....	31
Emergency Procedure.....	33

Asphalt Paver Requirements

A precondition for the safe use of the AC700 in accordance with applicable safety regulations is that the unit is only used on asphalt pavers that comply with the ap-

plicable safety regulation. The key safety requirements of asphalt pavers which have an influence on the safe use of AC700 is therefore outlined below.

Key safety requirements of asphalt pavers for the safe use of AC700



Within the EU the asphalt paver must be CE marked and thereby comply with the requirements described in EN60204, Safety on Machinery - Electrical Equipment of Machines



The asphalt paver must be equipped with an emergency stop that can stop all potentially dangerous parts of the machine, including switching off the power supply to the AC700



The asphalt paver must stop all potentially dangerous parts of the machine in case of a malfunction in the power supply, including switching off the power supply to the AC700



The AC700 is developed for use on both asphalt pavers with a 12V system and asphalt pavers with a 24V system. The asphalt paver must be able to deliver a stable power supply as described in EN60204, for instance via the battery of the asphalt paver

Key safety requirements for safe installation of AC700



The AC700 must be installed, mounted and connected in accordance with the instructions in this user manual



A form of overcurrent protection must be installed between the power supply of the asphalt paver and the AC700. This should be checked prior to the connection of the unit. The overcurrent protection is usually built into the asphalt paver in the form of a fuse in a central fuse box.

The short circuit breaking capacity must be adapted to the total maximum power consumption of the AC700, or equal the prospective fault current in case of short-circuiting. The maximum power consumption of the AC700 can be found under Technical Specifications (data sheets) p.60*



After installing the AC700 on a new asphalt paver, it should be tested that the emergency stop covers the system, so that the power supply to the AC700 is switched off when the emergency stop is activated

*TF-Technologies reserves the right to make changes in specifications without further notice.

Correct Use

The AC700 has been developed to regulate the level of material for an asphalt paver, and correct use therefore entails that the unit is used for this purpose. The AC700

should only be operated by a trained operator, so that personal injury and damaged equipment is avoided.

The operator must:



Read and understand the user manual
In case of questions, contact your local representative



Be aware of the situations described under Examples of Incorrect Use, p. 29, Warnings and Dangerous Situations, p. 31 and be able to avoid them



Be aware of the specifications of the AC700 to ensure it is working optimally. See Technical Specifications (data sheets) p. 60*

Responsibility of the Operator

When planning the paving job, the operator must remember the following:



Investigate local health and safety regulations and perform a risk assessment of the machine with the AC700 as a material controller in order to prevent any dangerous situations



Make sure the total risk assessment of the machine is accessible to everyone working with and around the asphalt paver



Make sure all personnel working with and around the asphalt paver understands how the material feed affects the paving job

When commencing the paving job, the operator must remember the following:



Avoid the situations described under Examples of Incorrect Use, p. 29 and Warnings and Dangerous Situations, p. 31



Avoid situations described in the total risk assessment



Ensure that the AC700 is not damaged



Ensure that the AC700 is connected correctly to the asphalt paver



Ensure that the AC700 is working within its specifications. See Technical Specifications (data sheets) p. 60*



Inform TF-Technologies or your local representative, if the AC700 for any reason is not safe to use

*TF-Technologies reserves the right to make changes in specifications without further notice.

Examples of Incorrect Use

The AC700 should only be used for what it is constructed to, and most examples of incorrect use are self-explanatory and therefore not described. However, certain

key examples of misuse or inappropriate behaviour are outlined below, and should be avoided.

Examples of incorrect use of the AC700 before the paving job



Do not remove any of the labels on the AC700, as they are required for product identification, e.g. in relation to repair and disposal



Do not open the aluminium house of the AC700, as this will expose the electronics and can damage the product



The AC700 must not be rebuilt or refurbished, as TF-Technologies will no longer be able to vouch for the quality, and rebuilding units may cause serious personal injury or material damage. The AC700 cables must not be disconnected from their connectors or in any way disassembled

Examples of incorrect use of the AC700 during the paving job



Do not use unauthorised cables or unauthorised spare parts, as this can damage the AC700 and lead to unpredictable control of the asphalt paver, which may result in serious personal injury or material damage



It is not recommended to connect the AC700 on a paver, when power is already applied, as the metal jacket on the cable under unfortunate circumstances may lead to short circuiting the asphalt paver, if the metal jacket hits the two power supply pins at the same time



It is not recommended to mount or adjust the AC700 on an asphalt paver on the move or in operation

- It can remove focus from the surrounding traffic, which may result in serious personal injuries
- It can remove focus from the moving parts of the machine, which may result in serious personal injuries
- The AC700 and cables can be dropped, squashed or otherwise damaged by the moving parts of the machine

Warnings and Dangerous Situations

The AC700 must not be used



If the AC700 or cable is obviously damaged



If the AC700 has been rebuilt



If the cable is for another type of machine, for instance if the cable uses another pin-out connection than the asphalt paver or the AC700



If the paver is regulated with other types of input than the output the AC700 is able to deliver

The AC700 can be damaged



If welding on the asphalt paver large currents may travel through the construction and damage the electrical equipment

The following precautions should be taken before welding:

- Remove all electrical equipment wherever possible
- Disconnect the negative pole on the battery of the asphalt paver, or mount voltage protection on the battery
- Place the negative electrode close to the welding point
- Remove paint before welding
- Remove flammable material to avoid ignition of sparks



When cleaning the asphalt paver, e.g. if using a high-pressure cleaner, as this may expose the AC700 to too large forces. The AC700 should therefore be removed before cleaning the asphalt paver

The AC700 can lead to serious personal injury



If an AC700 connected to the power supply is taken up to an ear or pointed towards others, as the ultrasound can damage the hearing. This is also the case, even if the ultrasound may not be audible



If warnings from the total risk assessment are not complied with



If the AC700 is operated by a person without training in operation and safe use, as he will not be able to observe the responsibility of the operator, cf. p. 27



If the AC700 is used in dangerous areas or in dangerous atmospheres/pressure levels, as the unit is not designed to such operation

Emergency Procedure

In case of accidents, break-downs or otherwise dangerous situations, the following procedure should be followed:

1.
2.
3.

- 1** Press emergency stop
- 2** Turn off the asphalt paver and remove the key
- 3** Disconnect the cable between the AC700 and the asphalt paver
- 4** Commence repair

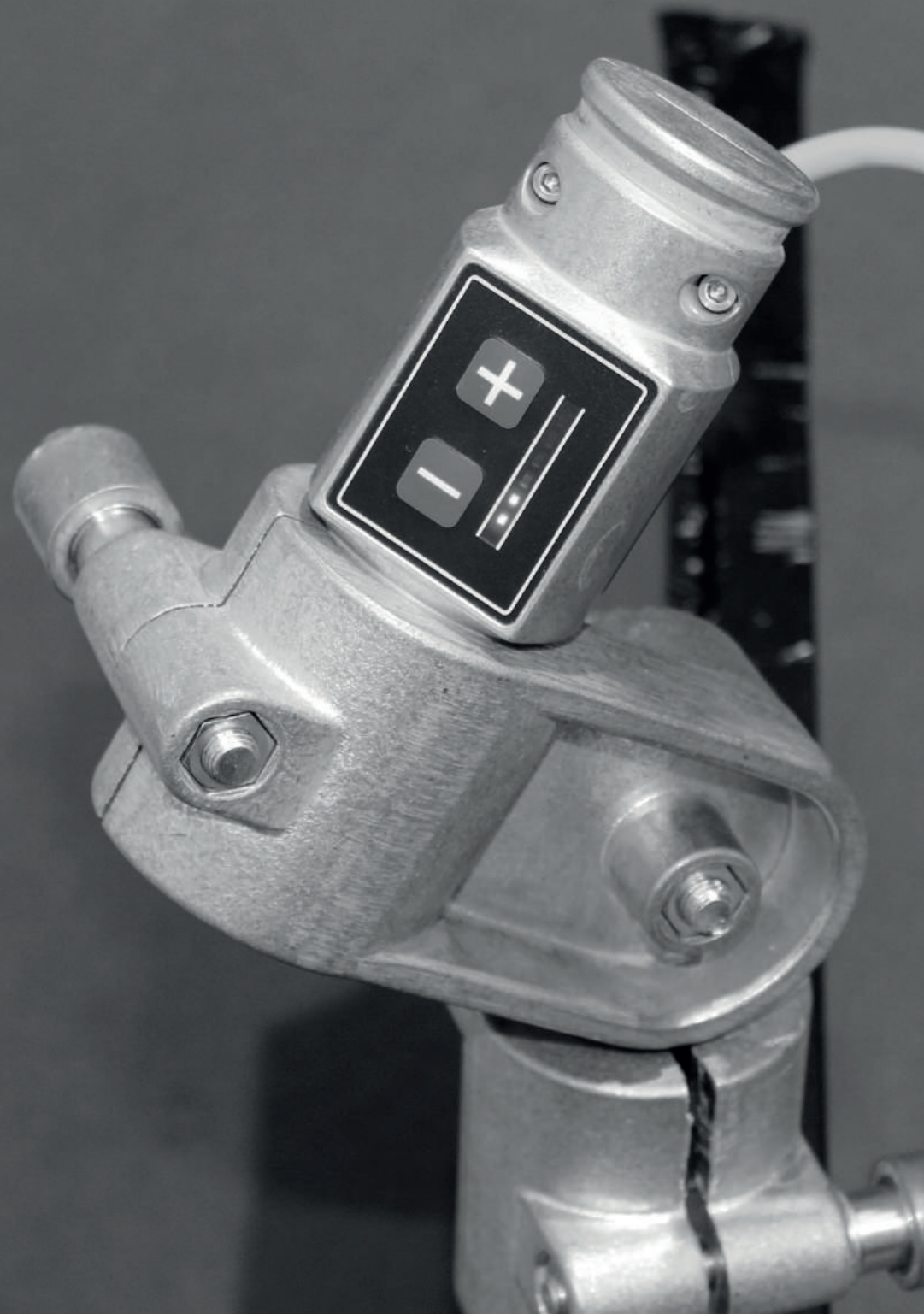



Mounting the AC700

Choosing Place of Operation	36
Placing the AC700	38
Incorrect Placement of the AC700	39
Mounting the AC700.....	40

Choosing Place of Operation

Most versions of the AC700 contain sensor and controller in one unit, and therefore the AC700 must be placed in an optimal location for both operation and measurements of the level of material. Most asphalt pavers already have mounting brackets for material

sensors that can be used for mounting the AC700, and these are already placed on the paver, however, there are still some considerations the operator should take into account before mounting the AC700.

Advice on choosing a safe place of operation:



The place of operation should to the extent possible be located outside of any dangerous areas, securing the operator from exposure to

- Ejection of objects from the machine or any machine emissions
- Moving parts of the asphalt paver
- Excessive radiant heat



From the place of operation, the operator should be able to ensure that no one is located in dangerous areas that can be affected by the operation of the AC700



Each place of operation should be within reach of the emergency stop, and if not physically possible, a colleague with access to the emergency stop must oversee the operator while he is operating the AC700



The place of operation should have sufficient room for the operator to move all parts of his body, and for him to use appropriate safety equipment



The place of operation should have easy access without any obstacles the operator can stumble upon or get his clothes caught in

General advice on mounting the AC700

If practically possible, the AC700 should be:



Easily accessible for operation and adjustments



Mounted so that the probability of material damages is minimized, e.g. where it is unexposed to the moving parts of the asphalt paver, excessive radiant heat, as well as potential shocks or pulls from the cable



Placed so that the unit can be oriented without the need to move any cables or other equipment



Placed in a position accessible for the operator that does not require him to bend or stretch unnecessarily



Placed so the display is clearly visible for the operator during the paving job

Placing the AC700

The AC700 can be used to control the material distribution from the augers, as well as the material feed from the conveyor belts, ensuring optimal feed and distribution of the asphalt hot mix, so that the material is distributed evenly across the screed providing a key precondition for a smooth road finish.

Auger control

For auger control, the ultrasonic sensor should point directly at the material in front of the auger, at the heap just before the side plate, to ensure that there is sufficient material across the full length of the screed.

Conveyor belt control

For conveyor belt control, the ultrasonic sensor should be directed at the point where the material is delivered from the conveyor belt to the auger, to ensure that there is sufficient material for the auger to distribute.

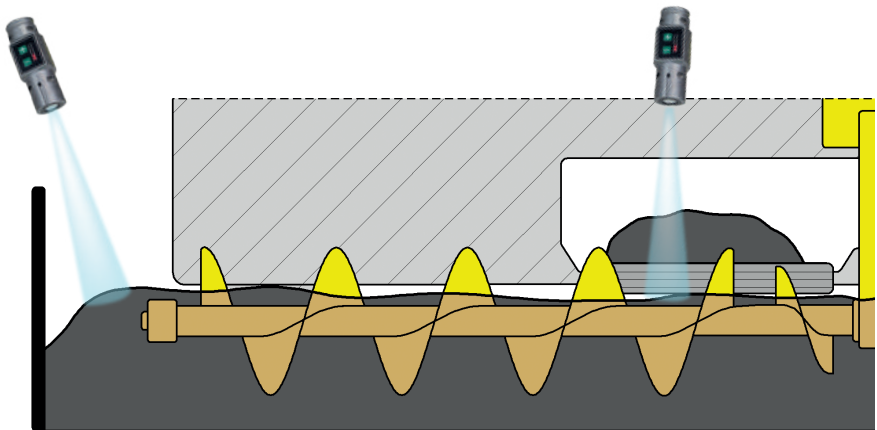

Figure 8 - Sensor placement seen from the back of the asphalt paver (just before the screed)

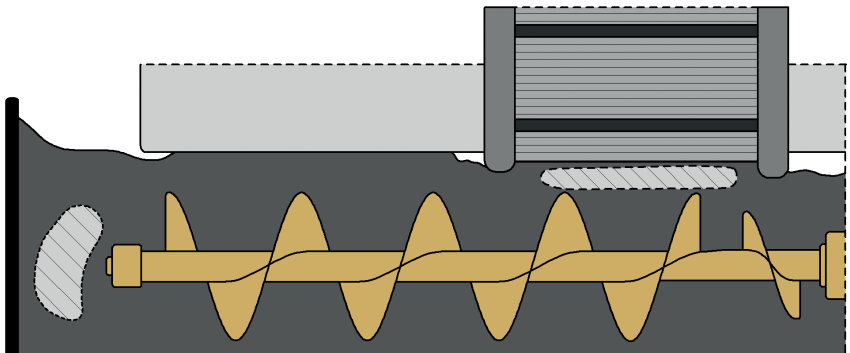
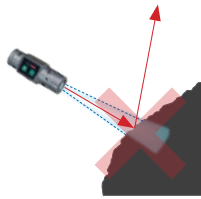
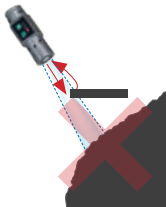

Figure 9 - Sensor placement seen from above. The ultrasonic sensor should point to the shaded areas in front of the auger for auger control and the conveyor belt for conveyor belt control

Incorrect Placement of the AC700



Avoid placing the AC700 at an oblique angle



Avoid objects which block the view of the sensor

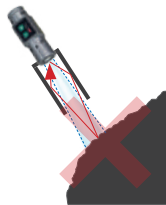

Avoid shielding the AC700

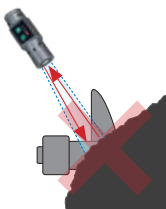

Avoid the AC700 pointing at the auger

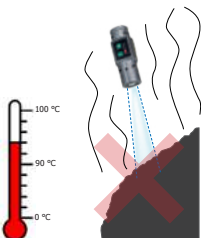

Avoid exposing the AC700 to temperatures above 70°C / 158°F

Avoid oblique angles

The AC700 sensor must be placed as perpendicular to the material as possible in order to achieve the optimal regulation of the material feed. In general, the sensor must point directly at the material, so that the measurements of the sensor correspond to the level of material. If the sensor is pointed towards the material in a sloped angle, it may not register the level of material correctly.

Avoid reflective sides or objects

No objects may block the view of the sensor, as they may reflect the ultrasonic waves and prevent the control of the material feed. The field of view of the sensor can be seen in the data sheet (p. 60) but as a rule of thumb there must be at least 150mm / 6" of free view from the middle and all around the sensor.

Avoid shielding the sensor

The sensor is unable to measure through a tube shielding its field of view. For example, if the mounting bracket is longer than the bottom of the sensor, so that the bracket extends beyond the sensor head, the sensor will not be able to function correctly.

Avoid pointing at the auger

The sensor may not point directly at the auger instead of the material. If the sensor points towards the auger, it will not be able to measure correctly when the level of material becomes lower than the distance to the auger. This can lead to a lack of material feed and a poor compaction, which can decrease the durability of the road.

Do not expose the AC700 to temperatures above 70°C / 158°F

The sensor may not be placed in a location where it may reach temperatures above 70°C / 158°F. If possible, the sensor should not be placed directly above the material or too close to the material. Especially when mounting the sensor for control of the material feed from the conveyor belts, the operator should be wary of high temperatures.

Mounting the AC700

Most asphalt pavers already contain mounting brackets for material sensors from the manufacturer that can be used for the mounting of AC700. However, it is important to make sure that the existing mounting bracket does not shield the field of view of the AC700, as this may affect the precision and results of the sensor.

Mounting in existing mounting bracket

When the AC700 is mounted at the conveyor belt, the mounting bracket is often simple and welded directly on the asphalt paver with the sensor pointing vertically down at the material.

When the AC700 is mounted correctly at the conveyor belt, no further adjustment of the position of the sensor is required.

The level of material at the conveyor belts typically only needs adjustment when the AC700 is mounted on the asphalt paver.



Mounting of AC700 on both conveyor belts

When the AC700 is mounted at the auger, the mounting bracket is typically more advanced and adjustable in several directions.

Every time the width of the screed is changed, it may be necessary to adjust the position of the AC700 slightly.

Typically the need for adjustment arises when the side plates are close to the auger,



Mounting bracket at conveyor belt



Mounting of the AC700 at the auger

and the sensor therefore ends up pointing at the auger instead of the material.

If the AC700 is mounted with an appropriate distance to the auger, adjustment of the sensor position is normally not required every time the side plate is adjusted to follow a joint or curb.

Mounting Bracket for AC700

Asphalt pavers without a suitable mounting bracket can use the TF-Technologies Mounting Bracket for Material Sensor, which ensures a flexible mounting and placement of the AC700 at an optimal angle.



Mounting Bracket for AC700, S-50521

When using the AC700 for auger control, the Mounting Bracket can be mounted on any available tube or knob, which is most often placed on the side plate of the screed for the mounting of material sensors.

The Mounting Bracket for the AC700 is easily adjusted, so that the operator can change the direction of the sensor head during the paving job.

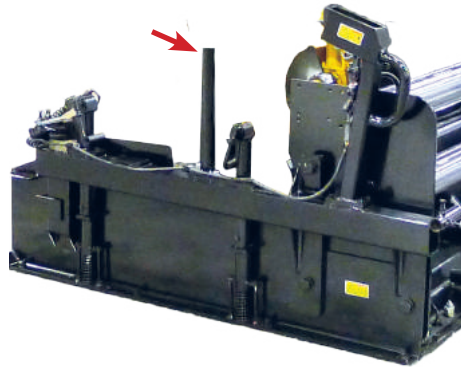

Tube on the side plate of an asphalt paver that can be used for mounting

When the side plate is moved during the paving job, the field of view of the AC700 is also changed, which may require the operator to adjust its mounting slightly.

The joints of the Mounting Bracket contains handles enabling the operator to make such small adjustments without the use of tools.

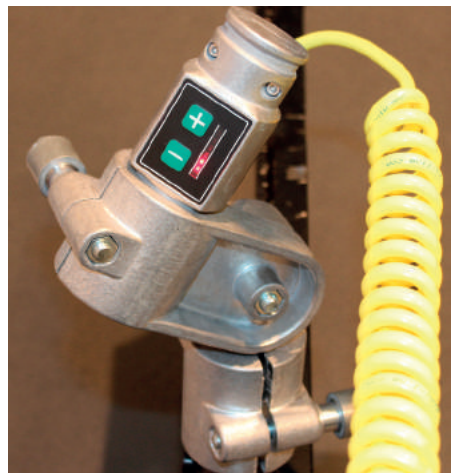

AC700 mounted in the Mounting Bracket





Connecting the AC700

Cables and Connections.....	44
Safe Connection and Disconnection	45

Cables and Connections

Connecting the AC700 is easily done with a single specialty cable, which is connected to the asphalt paver via the machine plug for material control of the asphalt paver.

As the AC700 exists in a number of different types with different specifications, a broad range of different AC700 cables is available, customized for the various types of AC700 and the different types of asphalt pavers. The operator must always ensure that the correct type of AC700 is connected with the correct type of cable.

All available cables for the AC700 are coiled and have a standard length of 4m / 13' fully extended, however connectors and pin-out vary. The correct choice of cable is determined by the particular brand and model of asphalt paver the unit is to be mounted on, cf. Choosing type of AC700 p. 11 for information.



An example of a cable for AC700



Before connecting the AC700, the operator must ensure that the chosen type of AC700 is correct and the chosen type of cable is correct and can be used on the particular asphalt paver the equipment is to be mounted on

Safe Connection and Disconnection

The AC700 is typically permanently mounted on the asphalt paver, and need not be connected and disconnected each time the asphalt paver is used. However, when necessary, the following instructions should be followed.

Step-by-step instructions for connecting the AC700

1.
2.
3.

1

Connect AC700

Turn off the asphalt paver. Connect AC700 with appropriate cable

2

Power on

Turn on the power from the asphalt paver. The display lights up briefly

3

Confirm connection

Confirm that the AC700 is connected correctly by pushing the buttons and reading the LED light diodes. Push the buttons to change the setpoint and choose the level of material required

Step-by-step instructions for disconnecting the AC700

1.
2.
3.

1

Power off

Turn off the asphalt paver

2

Remove unit

Disconnect the AC700 and cable from the asphalt paver

3

Store

Pack up and store the equipment safely for next time

Advice on connecting the AC700



Make sure the supply voltage is appropriate (12/24 volt system)



Make sure there is a fuse between the power supply of the asphalt paver and the plug for the AC700 before connecting the AC700



Only use cables that are verified can be used for the specific AC700 type and the particular asphalt paver. Incorrect pin-out can result in serious personal injury, as well as damage to the AC700 equipment and the asphalt paver



Never transfer different types of cables or different types of AC700 from one asphalt paver to another without verifying their suitability for the new machine. Incorrect pin-out can result in serious personal injury as well as damage to the AC700 equipment and the asphalt paver

Advice on protecting the cable while paving



The cable should not touch the ground and be prevented from dragging



The asphalt paver or other machinery should not be able to accidentally run over the cable



The cable should not be exposed to the moving parts of the asphalt paver



The cable should not be exposed to excessive radiant heat



The cable should not be exposed to repeated or large friction



The tow arm and the screed should be able to move freely without the cable becoming overly stretched or exposed to the moving parts of the asphalt paver



If the cable is too long, it should be twisted around a nearby tube or other, so that it is out of the way and prevented from dragging on the ground



TECHNOLOGIES
BRING INNOVATION



Maintenance

Maintenance	50
Inspection	50
Service and Repair	51
Transport.....	54
Storage	55
Cleaning	56
Disposal	57

Maintenance

The most important part of the maintenance of the AC700 and cables is to keep all parts clean, dry and dirt free. Remember to follow the cleaning instructions p. 56, as incorrect cleaning agents or too large forces can damage the equipment and cause degrading functionality.

Inspection

It is recommended to inspect all parts after use:

Part Exposed	Inspection	Frequency	Action
Cables	Mechanical damage	After use	Replace cable
Connectors on AC700 and Cables	Wet connectors	After use	Wipe off with dry cloth
	Mechanical damage	After use	Replace cable/ Replace connector on AC700
	Dirty	After use	Clean with water or Benzine
Sensor Head	Dirty	After use	Clean with water or Benzine
	Mechanical damage	After use	Replace sensor head
Buttons and Display	Dirty	After use	Clean with water or Benzine



Do not attempt to repair the equipment yourself. Replacement of connectors on the AC700 or any other parts must be undertaken by TF-Technologies or an appointed service representative of TF-Technologies. Contact your local representative for further information

Service and Repair

In case of the AC700 malfunctioning, it is recommended to test the unit with the following procedure before sending it in for repair:

Test of the AC700 materiale controller

1.
2.
3.

- 1** Connect the AC700 material controller to the machine plug that connects the controller to the auger or conveyor belt. This must be done while there is no material in the asphalt paver
- 2** Hold the AC700 above the ground, with the sensor pointing to the ground at a distance larger than 1000mm / 40" and wait for the error signal, where the two top and bottom LEDs flash alternately. Keep the AC700 away from your body and away from the paver so that the ultrasound is not reflected
 - Confirm that the auger/conveyor belt works
- 3** Hold the AC700 above the ground, with the sensor pointing to the ground at a distance larger than 1000mm / 40", and slowly move the sensor closer to the ground. Keep the AC700 away from your body and away from the paver, so that the ultrasound is not reflected
 - Verify that the error signal disappears and the setpoint is indicated with the light diodes
 - Confirm that the auger or conveyor belt starts to work, but stops when the distance to the ground is close to the setpoint. Indication of setpoint can be seen in the section Reading the AC700 Material Controller, p. 19

Test of the AC700 material sensor

1.
2.
3.

- 1** Connect the AC700 material sensor to the material controller of the asphalt paver (integrated or retrofitted). This must be done while there is no material in the asphalt paver.
- 2** Hold the AC700 above the ground, with the sensor pointing to the ground at a distance larger than 1000mm / 40 " and wait for the error signal, indicated with slow, short flashes of the green LED. Keep the AC700 away from your body and away from the paver so that the ultrasound is not reflected
- 3** Hold the AC700 above the ground, with the sensor pointing to the ground at a distance larger than 1000mm / 40 " and slowly move the sensor closer to the ground. Keep the AC700 away from your body and away from the paver so that the ultrasound is not reflected
 - Confirm that the error code disappears and that the green LED indicates that the sensor operates within range with slow flashes, where the LED is turned on and off an equal amount of time
 - Confirm that the auger/conveyor belt begins to operate, but stops when the distance to the ground is close to the setpoint

In case of malfunction during the test of AC700, it is recommended to complete the test in the other side of the asphalt paver, without moving the AC700 cable. If the unit tested works in the other side, the malfunction is either within the cable or the connection to the valve.

To test whether the malfunction is within the cable, it is recommended to try to switch the AC700 cables.

If the AC700 does not work as expected and as described in the test on the previous page, or in case of persistent problems, contact TF-Technologies or your local representative for assistance. The fault should be described and specified as well as possible. Please state all relevant information about the asphalt paver and any previous material controller/sensor, cf. About AC700 User Manual p. 4.

If the AC700 requires service or repair, please refer to the local representative of TF-Technologies.



Do not attempt to repair the AC700. Replacement of connectors or any other parts must be undertaken by TF-Technologies or an appointed service representative. Contact your local representative for further information



Service and repair of the AC700 undertaken by anyone else than TF-Technologies or an appointed service representative can result in serious personal injuries and/or damaged equipment

Transport

The AC700 is typically permanently mounted on the asphalt paver, and will only be kept separate from the paver, when the paver and the AC700 is undergoing maintenance or repair.

Advice on transport of the AC700:



The AC700 should be transported in a suitable carry case, where all parts rest firmly without being able to clash against each other.

- The AC700 should be separated from the cables so that the cables are protected against twisting
- The display and the sensor head of the AC700 must be protected from any sharp objects



The transport case must protect the equipment from shock and pressure, as the AC700 is often transported together with heavy equipment for the paving job



If the equipment is packed up wet, it should be wiped dry before storing

When receiving the AC700, the following should be inspected:



Are display, connectors and sensor head still intact?



Check the house for label and any loose connections, e.g. display and connectors



If the AC700 or cable has been damaged at reception, the following is recommended:

- Reject the package if it is visibly damaged (regress)
- Document any potential damage in the form of text and pictures
- Inform seller of the damages
- Do not use damaged products

Storage

Advice on storage of the AC700:



For long-term storage, the AC700 should be kept dry and out of direct sunlight



Notice that high temperatures can be obtained by storing the AC700 in a non-ventilated car in the summer



AC700 and cables should be stored and used within its temperature specifications

- Storage temperature: -40°C til 85°C
- Operating temperature: -10°C til 85°C

Cleaning

It is important that the AC700 is cleaned often, so that it does not lose functionality. However, inappropriate cleaning agents or an incorrect cleaning method can damage the equipment and cause degrading functionality.

It is generally recommended to use a dry cloth with a little **water** or **Benzine**, as the equipment is secured against water, and because Benzine evaporates quickly. A quick evaporation ensures that the Benzine does not collect in nooks and crannies and has long-term dissolving effects, as can be the case with other cleaning agents.

Please note that Benzine is an organic dissolvent, which is flammable and harmful to health and environment. It must therefore be used responsibly and with respect for its harmful effects. The operator should follow these instructions before use:



Follow the instructions on the bottle of Benzine



Always use as little as possible



Avoid breathing vapors and direct contact with the skin

When cleaning with fluids, only small amounts should be dapped on the areas to be cleaned, and these areas should be wiped with a dry cloth afterwards. The equipment must **never be submerged in chemical liquids** or exposed to cleaning agents in larger quantities, as the fluids can gather in nooks and crannies and have long-term dissolving effects.

Be particularly aware of:



No parts of the AC700 should be submerged in fluids as it may gather in nooks and crannies



Never use cellulose thinner or acetone, as these dissolve paint and plastic respectively, which will degrade the functionality of the equipment. Other cleaning agents can also be harmful, but experience shows that these two in particular should be avoided



Never use a high-pressure cleaner to remove dirt, as it will expose the equipment to too large forces



When mechanically rinsing the equipment, no scraping must be undertaken on the display, connectors or sensor head as these parts are particularly sensitive



The sensor head is porous and therefore able to draw liquids, which means the material can slowly dissolve if exposed to a dissolvent. The sensor head must therefore not be exposed to chemical liquids



Use of Benzine to clean cables can make the writing on the cables disappear, but the cables will not be damaged

Disposal

When disposing the AC700 the equipment must be treated as electronic waste in compliance with the local regulations of the country in which the equipment is disposed.

The responsibility for safe and appropriate disposal is transferred to the buyer in the sale of the AC700 equipment.





Appendix

Technical Specifications (data sheets)	60
Declarations of Conformity	73

Technical Specifications (data sheets)

AC700 material controller T1

AC700 Material Control for Asphalt Pavers

A key precondition to laying a smooth pavement is using a material control system to maintain a constant head of material in front of the screed.

The AC700 Material Controller monitors and regulates the material flow to maintain a constant level of material as set by the operator.

Controller and sensor is built into the same unit and is easy to install. It requires a minimum of maintenance as it uses ultrasonic non-contact sensing, which eliminates the problem of clogging material on mechanical sensors and removes the need for supervision in use.

It is operated with push buttons on an integrated keypad with an LED level indicator. The amount of material is easily changed by pushing either + or - on the keypad.



AC700 Material Control

AC700 Material Control Specifications	
Part Number	S-50631
Version	T1
Application	Auger or Conveyor Material Buildup Control
Power Supply	12/24 Volt System (10-30 VDC)
Power Consumption	Typical at 24 VDC 70 mA Max. 200 mA
Dimensions (LxWxH)	130x53x67mm
Weight	0.35kg
House	Aluminium
Storage Temperature	-40°C to 85°C
Operating Temperature	-10°C to 85°C
Sensor Type	1x 125kHz Ultrasonic Transducer
Transducer Beam Width (-3dB full angle)	12° +/- 2°
Sensor Range	200-1000mm
Connector	6-Pin Bayonet, Male A: Vbat D: Output 2 B: GND E: NC C: Output 1 F: NC
Output	Output 1: PNP ON/OFF (Max. 3A) Output 2: NPN ON/OFF (Max. 3A)
Level Adjustment Steps	21 mm

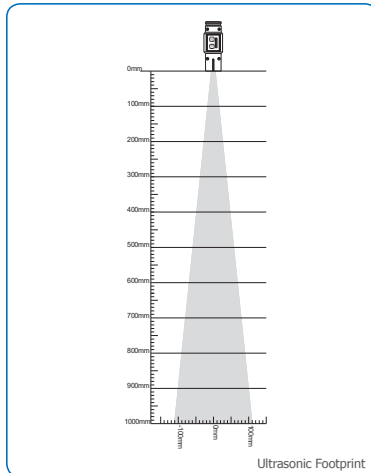

TF-Technologies reserves the right to make changes without further notice.

v. H801803

AC700 material controller T2

AC700 Material Control for Asphalt Pavers

A key precondition to laying a smooth pavement is using a material control system to maintain a constant head of material in front of the screed.

The AC700 Material Controller monitors and regulates the material flow to maintain a constant level of material as set by the operator.

Controller and sensor is built into the same unit and is easy to install. It requires a minimum of maintenance as it uses ultrasonic non-contact sensing, which eliminates the problem of clogging material on mechanical sensors and removes the need for supervision in use.

It is operated with push buttons on an integrated keypad with an LED level indicator. The amount of material is easily changed by pushing either + or - on the keypad.



AC700 Material Control

AC700 Material Control Specifications	
Part Number	S-50632
Version	T2
Application	Auger or Conveyor Material Buildup Control
Power Supply	12/24 Volt System (10-30 VDC)
Internal Power Consumption	Typical at 24 VDC 70 mA Max. 200 mA
Dimensions (LxWxH)	130x53x67mm
Weight	0.35kg
House	Aluminium
Storage Temperature	-40°C to 85°C
Operating Temperature	-10°C to 85°C
Sensor Type	1x 125kHz Ultrasonic Transducer
Transducer Beam Width (-3dB full angle)	12° +/- 2°
Sensor Range	200-1000mm
Connector	6-Pin Bayonet, Male A: Vbat D: Output 2 B: GND E: NC C: Output 1 F: NC
Output	Output 1: PNP PWM (Max. 2A) Output 2: NPN PWM (Max. 2A)
Level Adjustment Steps	21 mm

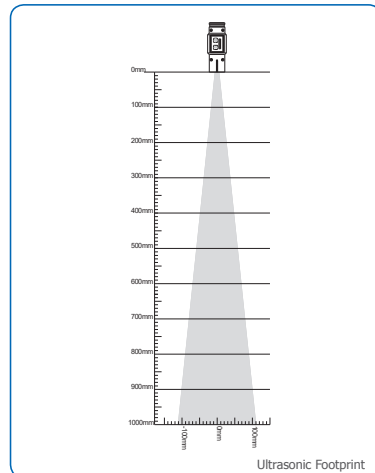

Ultrasonic Footprint

TF-Technologies reserves the right to make changes without further notice.

v. H801903

TF-Technologies A/S
Kratbjerg 214

DK-3480 Fredensborg
Phone: +45 4848 2633

www.tf-technologies.com
sales@tf-technologies.com

AC700 material controller T3

AC700 Material Control for Asphalt Pavers

A key precondition to laying a smooth pavement is using a material control system to maintain a constant head of material in front of the screed.

The AC700 Material Controller monitors and regulates the material flow to maintain 2 constant level of material as set by the operator.

Controller and sensor is built into the same unit and is easy to install. It requires a minimum of maintenance as it uses ultrasonic non-contact sensing, which eliminates the problem of clogging material on mechanical sensors and removes the need for supervision in use.

It is operated with push buttons on an integrated keypad with an LED level indicator. The amount of material is easily changed by pushing either + or - on the keypad.



AC700 Material Control

AC700 Material Control Specifications	
Part number	S-50633
Version	T3
Application	Auger or Conveyor Material Buildup Control
Power Supply	12/24 Volt System (10-30 VDC)
Internal Power Consumption	Typical at 24 VDC 70 mA Max. 200 mA
Dimensions (LxWxH)	130x53x67mm
Weight	0.35kg
House	Aluminium
Storage temperature	-40°C to 85°C
Operating temperature	-10°C to 85°C
Sensor type	1x 125kHz Ultrasonic Transducer
Transducer Beam Width (-3dB full angle)	12° +/- 2°
Sensor Range	200-1000mm
Connector	6-Pin Screw, Male A: Vbat D: Output B: NC E: NC C: GND F: NC
Output	PNP PWM (Max. 2A)
Level Adjustment Steps	21 mm

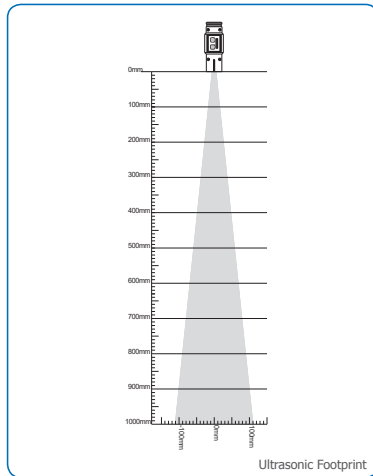

Ultrasonic Footprint

TF-Technologies reserves the right to make changes without further notice.

v. H802003

AC700 material controller T4

AC700 Material Control for Asphalt Pavers

A key precondition to laying a smooth pavement is using a material control system to maintain a constant head of material in front of the screed.

The AC700 Material Controller monitors and regulates the material flow to maintain a constant level of material as set by the operator.

Controller and sensor is built into the same unit and is easy to install. It requires a minimum of maintenance as it uses ultrasonic non-contact sensing, which eliminates the problem of clogging material on mechanical sensors and removes the need for supervision in use.

It is operated with push buttons on an integrated keypad with an LED level indicator. The amount of material is easily changed by pushing either + or – on the keypad.



AC700 Material Control

AC700 Material Control Specifications	
Part Number	S-50634
Version	T4
Application	Auger or Conveyor Material Buildup Control
Power Supply	12..30 VDC
Internal Power Consumption	Max 200 mA
Dimensions (LxWxH)	130x53x67mm
Weight	0.35kg
House	Aluminium
Storage Temperature	-40°C to 85°C
Operating Temperature	-10°C to 85°C
Sensor Type	1x 125kHz Ultrasonic Transducer
Transducer Beam Width (-3dB full angle)	12° +/- 2°
Sensor Range	200-1000mm
Connector	5-Pin Screw, Male A: Vbat D: Output B: GND E: NC C: NC
Output	PNP ON/OFF (Max. 3A)
Level Adjustment Steps	21 mm

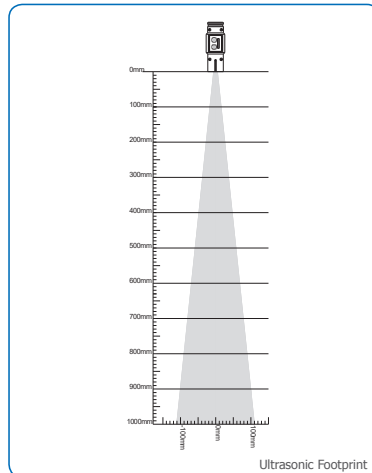

Ultrasonic Footprint

TF-Technologies reserves the right to make changes without further notice.

v. H802103

TF-Technologies A/S
Kratbjerg 214

DK-3480 Fredensborg
Phone: +45 4848 2633

www.tf-technologies.com
sales@tf-technologies.com

AC700 material controller T5

AC700 Material Control for Asphalt Pavers

A key precondition to laying a smooth pavement is using a material control system to maintain a constant head of material in front of the screed.

The AC700 Material Controller monitors and regulates the material flow to maintain a constant level of material as set by the operator.

Controller and sensor is built into the same unit and is easy to install. It requires a minimum of maintenance as it uses ultrasonic non-contact sensing, which eliminates the problem of clogging material on mechanical sensors and removes the need for supervision in use.

It is operated with push buttons on an integrated keypad with an LED level indicator. The amount of material is easily changed by pushing either + or - on the keypad.



AC700 Material Control

AC700 Material Control Specifications	
Part Number	S-50635
Version	T5
Application	Auger or Conveyor Material Buildup Control
Power Supply	12/24 Volt System (10-30 VDC)
Internal Power Consumption	Typical at 24 VDC 70 mA Max. 200 mA
Dimensions (LxWxH)	130x53x67mm
Weight	0.35kg
House	Aluminium
Storage Temperature	-40°C to 85°C
Operating Temperature	-10°C to 85°C
Sensor Type	1x 125kHz Ultrasonic Transducer
Transducer Beam Width (-3dB full angle)	12° +/- 2°
Sensor Range	200-1000mm
Connector	6-Pin Screw, Male A: Output 1 D: NC B: GND E: Output 2 C: Vbat F: NC
Output	Output 1: NPN ON/OFF (Max. 3A) Output 2: Voltage Output
Level Adjustment Steps	21 mm

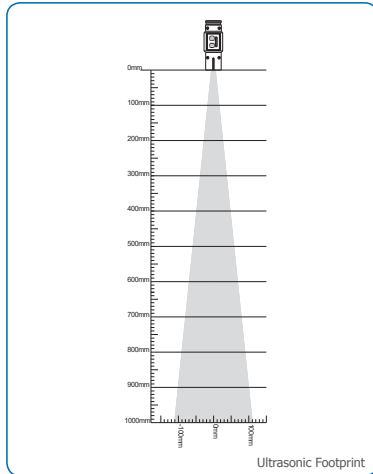

Ultrasonic Footprint

TF-Technologies reserves the right to make changes without further notice.

v. H802203

AC700 material controller T6

AC700 Material Control for Asphalt Pavers

A key precondition to laying a smooth pavement is using a material control system to maintain a constant head of material in front of the screed.

The AC700 Material Controller monitors and regulates the material flow to maintain a constant level of material as set by the operator.

Controller and sensor is built into the same unit and is easy to install. It requires a minimum of maintenance as it uses ultrasonic non-contact sensing, which eliminates the problem of clogging material on mechanical sensors and removes the need for supervision in use.

It is operated with push buttons on an integrated keypad with an LED level indicator. The amount of material is easily changed by pushing either + or - on the keypad.



AC700 Material Control

AC700 Material Control Specifications	
Part Number	S-50636
Version	T6
Application	Auger or Conveyor Material Buildup Control
Power Supply	12/24 Volt System (10-30 VDC)
Internal Power Consumption	Typical at 24 VDC 70 mA Max. 200 mA
Dimensions (LxWxH)	130x53x67mm
Weight	0.35kg
House	Aluminium
Storage Temperature	-40°C to 85°C
Operating Temperature	-10°C to 85°C
Sensor Type	1x 125kHz Ultrasonic Transducer
Transducer Beam Width (-3dB full angle)	12° +/- 2°
Sensor Range	200-1000mm
Connector	5-Pin Screw, Male A: Vbat D: Output B: GND E: NC C: NC
Output	PNP PWM (Max. 2A)
Level Adjustment Steps	21 mm

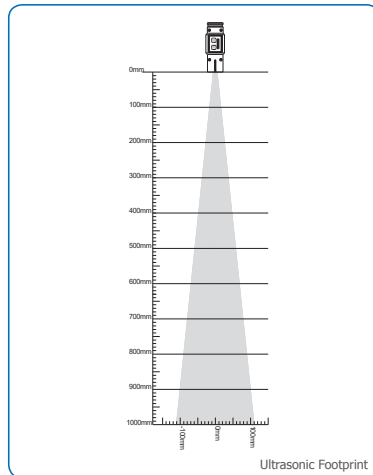

Ultrasonic Footprint

TF-Technologies reserves the right to make changes without further notice.

v. H802303

TF-Technologies A/S
Kratbjerg 214

DK-3480 Fredensborg
Phone: +45 4848 2633

www.tf-technologies.com
sales@tf-technologies.com

AC700 material sensor T7

AC700 Material Sensor for Asphalt Pavers

A key precondition to laying a smooth pavement is using a material control system to maintain a constant head of material in front of the screed.

The AC700 Material Sensor monitors and signals the actual level of material to a controller. The controller will then be able to regulate the material flow to maintain a constant level of material.

The sensor requires a minimum of maintenance as it uses ultrasonic non-contact sensing which eliminates the problem of clogging material on mechanical sensors and removes the need for supervision in use.

It has an LED indicator used for indication of sensor status.



AC700 Material Sensor

AC700 Material Sensor Specifications	
Part Number	S-S0637
Version	T7
Application	Auger or Conveyor Material Buildup Sensor
Power Supply	12/24 Volt System (10-30 VDC)
Power Consumption	Typical at 24 VDC 70 mA Max. 200 mA
Dimensions (LxWxH)	130x53x67mm
Weight	0.35kg
House	Aluminium
Storage Temperature	-40°C to 85°C
Operating Temperature	-10°C to 85°C
Sensor Type	1x 125KHz Ultrasonic Transducer
Transducer Beam Width (-3dB full angle)	12° +/- 2°
Sensor Range	200-1000mm
Connector	5-Pin Screw, Male A: Vbat D: NC B: GND E: NC C: Output
Output	Voltage Output

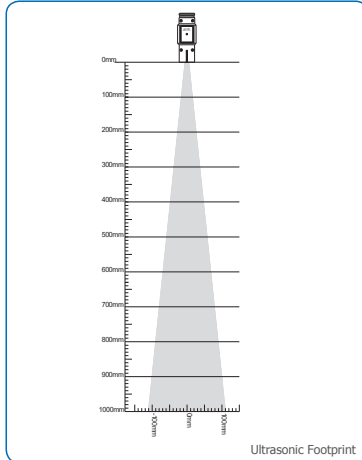

TF-Technologies reserves the right to make changes without further notice.

v. H805902

AC700 material controller T8

AC700 Material Control for Asphalt Pavers

A key precondition to laying a smooth pavement is using a material control system to maintain a constant head of material in front of the screed.

The AC700 Material Controller monitors and regulates the material flow to maintain a constant level of material as set by the operator.

Controller and sensor is built into the same unit and is easy to install. It requires a minimum of maintenance as it uses ultrasonic non-contact sensing, which eliminates the problem of clogging material on mechanical sensors and removes the need for supervision in use.

It is operated with push buttons on an integrated keypad with an LED level indicator. The amount of material is easily changed by pushing either + or - on the keypad.



AC700 Material Control Specifications	
Part Number	S-50638
Version	T8
Application	Auger or Conveyor Material Buildup Control
Power Supply	12/24 Volt System (10-30 VDC)
Power Consumption	Typical at 24 VDC 70 mA Max. 200 mA
Dimensions (LxWxH)	130x53x67mm
Weight	0.35kg
House	Aluminium
Storage Temperature	-40°C to 85°C
Operating Temperature	-10°C to 85°C
Sensor Type	1x 125KHz Ultrasonic Transducer
Transducer Beam Width (-3dB full angle)	12" +/- 2"
Sensor Range	200-1000mm
Connector	6-Pin Screw, Male A: Vbat D: Output B: GND E: NC C: NC F: NC
Output	Voltage Output
Level Adjustment Steps	21 mm

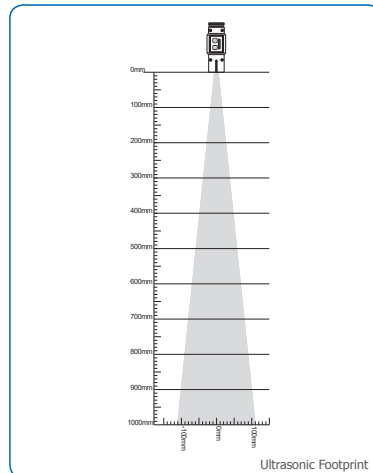

TF-Technologies reserves the right to make changes without further notice.

v. H806002

TF-Technologies A/S
Kratbjerg 214

DK-3480 Fredensborg
Phone: +45 4848 2633

www.tf-technologies.com
sales@tf-technologies.com

AC700 material sensor T9

AC700 Material Sensor for Asphalt Pavers

A key precondition to laying a smooth pavement is using a material control system to maintain a constant head of material in front of the screed.

The AC700 Material Sensor monitors and signals the actual level of material to a controller. The controller will then be able to regulate the material flow to maintain a constant level of material.

The sensor requires a minimum of maintenance as it uses ultrasonic non-contact sensing which eliminates the problem of clogging material on mechanical sensors and removes the need for supervision in use.

It has an LED indicator used for indication of sensor status.



AC700 Material Sensor

AC700 Material Sensor Specifications	
Part Number	S-50639
Version	T9
Application	Auger or Conveyor Material Buildup Sensor
Power Supply	12/24 Volt System (10-30 VDC)
Power Consumption	Typical at 24 VDC 70 mA Max. 200 mA
Dimensions (LxWxH)	130x53x67mm
Weight	0.35kg
House	Aluminium
Storage Temperature	-40°C to 85°C
Operating Temperature	-10°C to 85°C
Sensor Type	1x 125KHz Ultrasonic Transducer
Transducer Beam Width (-3dB full angle)	12° +/- 2°
Sensor Range	200-1000mm
Connector	6-Pin Screw, Male A: Vbat D: NC B: GND E: NC C: Output F: NC
Output	NPN PWM (max. 0.5A)

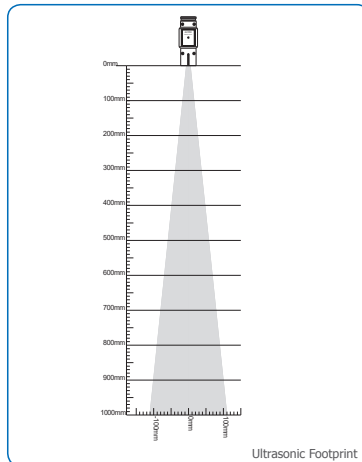

Ultrasonic Footprint

TF-Technologies reserves the right to make changes without further notice.

v. H806102

AC700 material controller T12

AC700 Material Sensor for Asphalt Pavers

A key precondition to laying a smooth pavement is using a material control system to maintain a constant head of material in front of the screed.

The AC700 Material Sensor monitors and signals the actual level of material to a controller. The controller will then be able to regulate the material flow to maintain a constant level of material.

The sensor requires a minimum of maintenance as it uses ultrasonic non-contact sensing which eliminates the problem of clogging material on mechanical sensors and removes the need for supervision in use.

It has an LED indicator used for indication of sensor status.



AC700 Material Sensor

AC700 Material Sensor Specifications	
Part Number	S-50642
Version	T12
Application	Auger or Conveyor Material Buildup Sensor
Power Supply	12/24 Volt System (10-30 VDC)
Power Consumption	Typical at 24 VDC 70 mA Max. 200 mA
Dimensions (LxWxH)	130x53x67mm
Weight	0.35kg
House	Aluminium
Storage Temperature	-40°C to 85°C
Operating Temperature	-10°C to 85°C
Sensor Type	1x 125KHz Ultrasonic Transducer
Transducer Beam Width (-3dB full angle)	12" +/- 2"
Sensor Range	200-1000mm
Connector	6-Pin Screw, Male A: Vbat D: NC B: Output E: GND C: GND F: NC
Output	Voltage Output

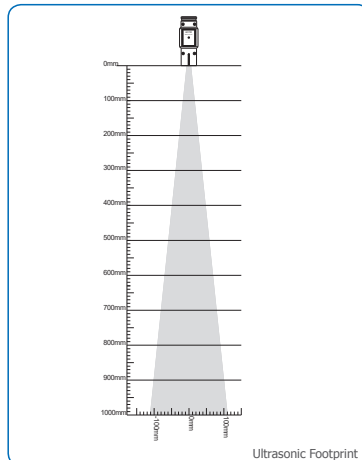

TF-Technologies reserves the right to make changes without further notice.

v. H811402

TF-Technologies A/S
Kratbjerg 214

DK-3480 Fredensborg
Phone: +45 4848 2633

www.tf-technologies.com
sales@tf-technologies.com

AC700 material controller T13

AC700 Material Sensor for Asphalt Pavers

A key precondition to laying a smooth pavement is using a material control system to maintain a constant head of material in front of the screed.

The AC700 Material Sensor monitors and signals the actual level of material to a controller. The controller will then be able to regulate the material flow to maintain a constant level of material.

The sensor requires a minimum of maintenance as it uses ultrasonic non-contact sensing which eliminates the problem of clogging material on mechanical sensors and removes the need for supervision in use.

It has an LED indicator used for indication of sensor status.



AC700 Material Sensor

AC700 Material Sensor Specifications	
Part Number	S-50643
Version	T13
Application	Auger or Conveyor Material Buildup Sensor
Power Supply	12/24 Volt System (10-30 VDC)
Power Consumption	Typical at 24 VDC 70 mA Max. 200 mA
Dimensions (LxWxH)	130x53x67mm
Weight	0.35kg
House	Aluminium
Storage Temperature	-40°C to 85°C
Operating Temperature	-10°C to 85°C
Sensor Type	1x 125kHz Ultrasonic Transducer
Transducer Beam Width (-3dB full angle)	12" +/- 2"
Sensor Range	200-1000mm
Connector	4-Pin Valve, Male 1: Output 2: NC 3: Vbat GND: GND
Output	Voltage Output

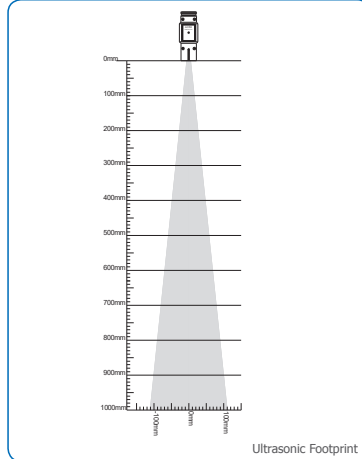

Ultrasonic Footprint

TF-Technologies reserves the right to make changes without further notice.

v. H811503

AC700 material controller T14

AC700 Material Control for Asphalt Pavers

A key precondition to laying a smooth pavement is using a material control system to maintain a constant head of material in front of the screed.

The AC700 Material Controller monitors and regulates the material flow to maintain a constant level of material as set by the operator.

Controller and sensor is built into the same unit and is easy to install. It requires a minimum of maintenance as it uses ultrasonic non-contact sensing, which eliminates the problem of clogging material on mechanical sensors and removes the need for supervision in use.

It is operated with push buttons on an integrated keypad with an LED level indicator. The amount of material is easily changed by pushing either + or – on the keypad.



AC700 Material Control

AC700 Material Control Specifications	
Part Number	S-50844
Version	T14
Application	Auger or Conveyor Material Buildup Control
Power Supply	12/24 Volt System (10-30 VDC)
Internal Power Consumption	Typical at 24 VDC 70 mA Max. 200 mA
Dimensions (LxWxH)	130x53x67mm
Weight	0.35kg
House	Aluminium
Storage Temperature	-40°C to 85°C
Operating Temperature	-10°C to 85°C
Sensor Type	1x 125kHz Ultrasonic Transducer
Transducer Beam Width (-3dB full angle)	12° +/- 2°
Sensor Range	200-1000mm
Connector	6-Pin Screw, Male A: Vbat D: Output B: NC E: NC C: GND F: NC
Output	PNP PWM (Max. 2A)
Level Adjustment Steps	21 mm

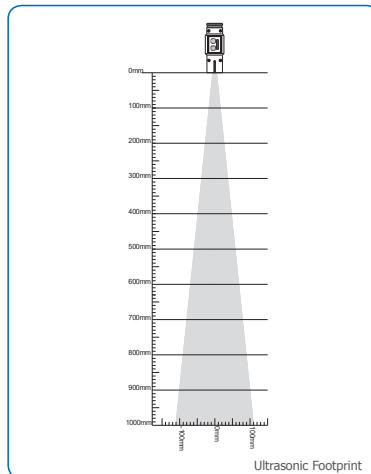

TF-Technologies reserves the right to make changes without further notice.

v. H802403

TF-Technologies A/S
Kratbjerg 214

DK-3480 Fredensborg
Phone: +45 4848 2633

www.tf-technologies.com
sales@tf-technologies.com

AC700 material controller T16

AC700 Material Control for Asphalt Pavers

A key precondition to laying a smooth pavement is using a material control system to maintain a constant head of material in front of the screed.

The AC700 Material Controller monitors and regulates the material flow to maintain a constant level of material as set by the operator.

Controller and sensor is built into the same unit and is easy to install. It requires a minimum of maintenance as it uses ultrasonic non-contact sensing, which eliminates the problem of clogging material on mechanical sensors and removes the need for supervision in use.

It is operated with push buttons on an integrated keypad with an LED level indicator. The amount of material is easily changed by pushing either + or - on the keypad.



AC700 Material Control

AC700 Material Control Specifications	
Part Number	S-S0646
Version	T16
Application	Auger or conveyor material buildup control
Power Supply	12/24 Volt System (10-30 VDC)
Internal Power Consumption	Typical at 24 VDC 70 mA Max. 200 mA
Dimensions (LxWxH)	130x53x67mm
Weight	0.35kg
House	Aluminium
Storage Temperature	-40°C to 85°C
Operating Temperature	-10°C to 85°C
Sensor Type	1x 125KHz Ultrasonic Transducer
Transducer Beam Width (-3dB full angle)	12" +/- 2"
Sensor Range	200-1000mm
Connector	6-Pin Bayonet, Male A: Vbat D: NC B: GND E: NC C: Output F: NC
Output	PNP Current
Level Adjustment Steps	21 mm

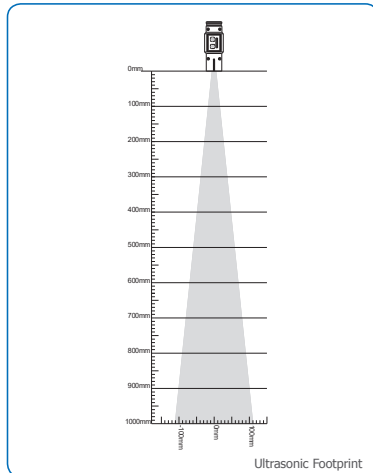

Ultrasonic Footprint

TF-Technologies reserves the right to make changes without further notice.

v. H802503

TF-Technologies A/S
Kratbjerg 214

DK-3480 Fredensborg
Phone: +45 4848 2633

www.tf-technologies.com
sales@tf-technologies.com

Declarations of Conformity



EC Declaration of Conformity
 Document no.: J9004401
 Published: March 6, 2014

EC Declaration of Conformity

Electromagnetic Conformity Directive 2004/108/EC

Manufacturer within European Community

COMPANY NAME TF-Technologies A/S
 ADDRESS Kratbjerg 214
 3480 Fredensborg
 Denmark

Description of Product

PRODUCT NAME AC700 Material Control
 MODELS T01, T02, T03, T04, T05, T06, T08, T14 and T16
 APPLICATION Auger or conveyor material buildup control
 PART NUMBER S-50631 S-50632 S-50633 S-50634 S-50635
 S-50636 S-50638 S-50644 S-50646

Conformity and Assessment Procedure Followed

DIRECTIVE Electromagnetic Conformity Directive 2004/108/EC
 HARMONIZED STANDARD EN 13309:2010 – Construction machinery
 - Electromagnetic compatibility of machines with internal power supply
 TEST METHOD ISO 10605
 ISO 11452-2
 CISPR 25
 ISO 7637-2

Additional Compliance

HARMONIZED STANDARD EN 60204-1:2006+A1:2009 – Safety of machinery
 - Electrical equipment of machines: General requirements
 (Harmonized standard under the Machinery Directive 2006/42/ec)

Valid if both installation and use follow the instructions of TF-Technologies A/S

March 6, 2014

Lisbeth Teilmann Melchior, CEO, TF-Technologies A/S



EC Declaration of Conformity
 Document no.: J9004501
 Published: March 6, 2014

EC Declaration of Conformity

Electromagnetic Conformity Directive 2004/108/EC

Manufacturer within European Community

COMPANY NAME TF-Technologies A/S
 ADDRESS Kratbjerg 214
 3480 Fredensborg
 Denmark

Description of Product

PRODUCT NAME AC700 Material Sensor
 MODELS T07 and T09
 APPLICATION Auger or conveyor material buildup monitoring
 PART NUMBER S-50637 S-50639

Conformity and Assessment Procedure Followed

DIRECTIVE Electromagnetic Conformity Directive 2004/108/EC
 HARMONIZED STANDARD EN 13309:2010 – Construction machinery
 - Electromagnetic compatibility of machines with internal power supply
 TEST METHOD ISO 10605
 ISO 11452-2
 CISPR 25
 ISO 7637-2

Valid if both installation and use follow the instructions of TF-Technologies A/S

March 6, 2014

 Lisbeth Teilmann Melchior, CEO, TF-Technologies A/S

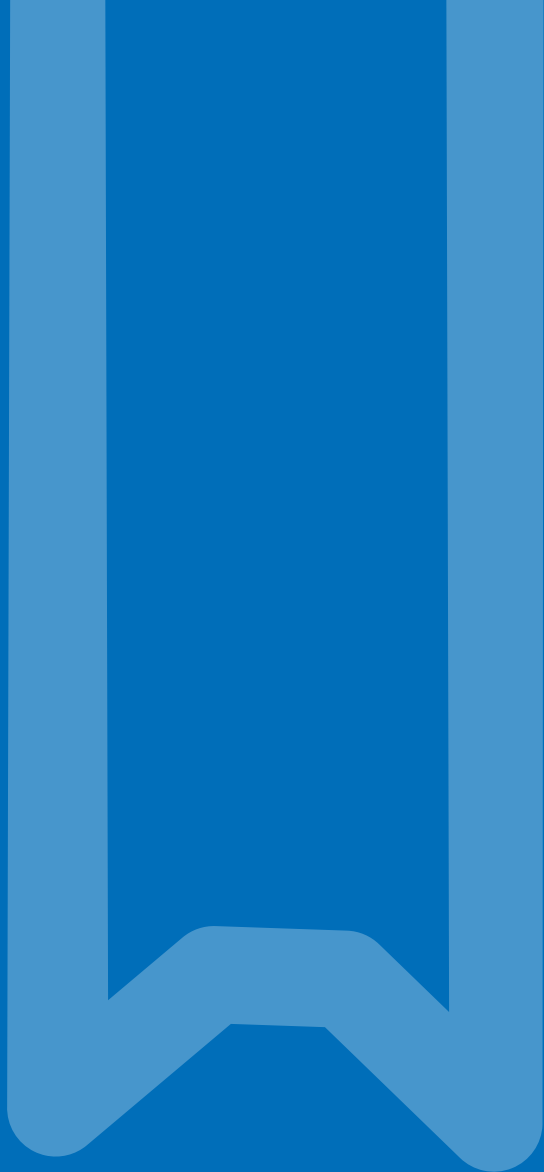

tf TECHNOLOGIES
PAVING INNOVATION

Kratbjerg 214 - DK 3480 Fredensborg - Denmark - Phone: +45 48 48 26 33 - Email: sales@tf-technologies.com
www.tf-technologies.com